

LM02 The Time Value of Money in Finance

1. Introduction.....	2
2. Time Value of Money in Fixed Income and Equity	2
3. Implied Return and Growth.....	10
4. Cash Flow Additivity	13
Summary.....	21

This document should be read in conjunction with the corresponding reading in the 2024 Level I CFA® Program curriculum. Some of the graphs, charts, tables, examples, and figures are copyright 2024, CFA Institute. Reproduced and republished with permission from CFA Institute. All rights reserved.

Required disclaimer: CFA Institute does not endorse, promote, or warrant the accuracy or quality of the products or services offered by IFT. CFA Institute, CFA®, and Chartered Financial Analyst® are trademarks owned by CFA Institute.

Ver 1.0

1. Introduction

In this learning module we will apply time value of money principles to value financial assets. This learning module covers:

- Calculating the present value of fixed-income and equity instruments based on their expected cash flows.
- Calculating implied bond and stock returns given their current market prices.
- Applying the cash flow additivity and no-arbitrage principles to calculate implied forward interest rates, forward exchange rates, and option values.

2. Time Value of Money in Fixed Income and Equity

The relationship between present value (PV) and future value (FV) of a cash flow is:

$$FV_t = PV(1 + r)^t$$

where:

r = stated discount rate per period

t = number of compounding periods

With continuous compounding the relationship can be expressed as:

$$FV_t = PVe^{rt}$$

We can also rearrange the above equations and express present value in terms of future values as:

$$PV = \frac{FV_t}{(1 + r)^t}$$

$$PV = \frac{FV_t}{e^{rt}}$$

Fixed-Income Instruments and the Time Value of Money

Fixed-income instruments are debt instruments such as a bond or a loan. Depending on the types of cash flows provided we can divide them into three types:

- Discount instruments
- Coupon instruments
- Annuity instruments

Discount instruments: A debt security that does not pay interest but is instead issued at a deep discount. At maturity the security is redeemed for its full face value. The difference between the face value and issue price represents interest earned over the life of the instrument. E.g., zero-coupon bonds.

Exhibit 1 from the curriculum illustrates the cash flow pattern of a zero-coupon bond (aka discount bond).

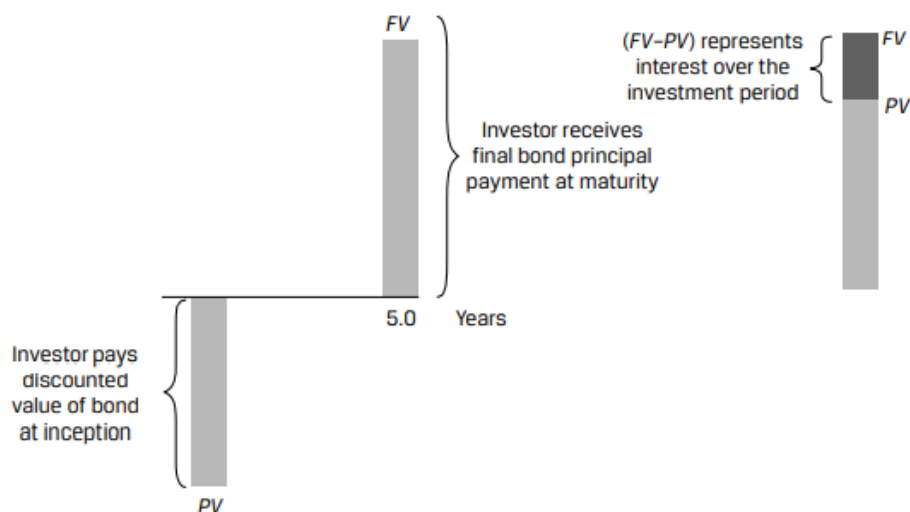

The present value (PV) of a zero-coupon bond can be calculated as:

$$PV = \frac{FV_t}{(1 + r)^t}$$

where:

FV_t = principal amount received at maturity

r = market discount rate

Example:

(This is based on Example 1 from the curriculum.)

Consider a 20 year zero-coupon bond issued at a yield to maturity (YTM) of 6.70%. What should an investor expect to pay for this bond per INR100 of principal?

Solution:

The YTM of a bond at issuance is the market discount rate at issuance. The PV of this bond can be calculated as:

$$PV = \frac{100}{(1 + 0.067)^{20}} = 27.33$$

Coupon instruments: These are regular bonds that make periodic coupon payments and repay principal at maturity. E.g., Coupon paying corporate bonds.

Exhibit 2 from the curriculum illustrates the cash flow pattern of a semi-annual coupon paying bond.

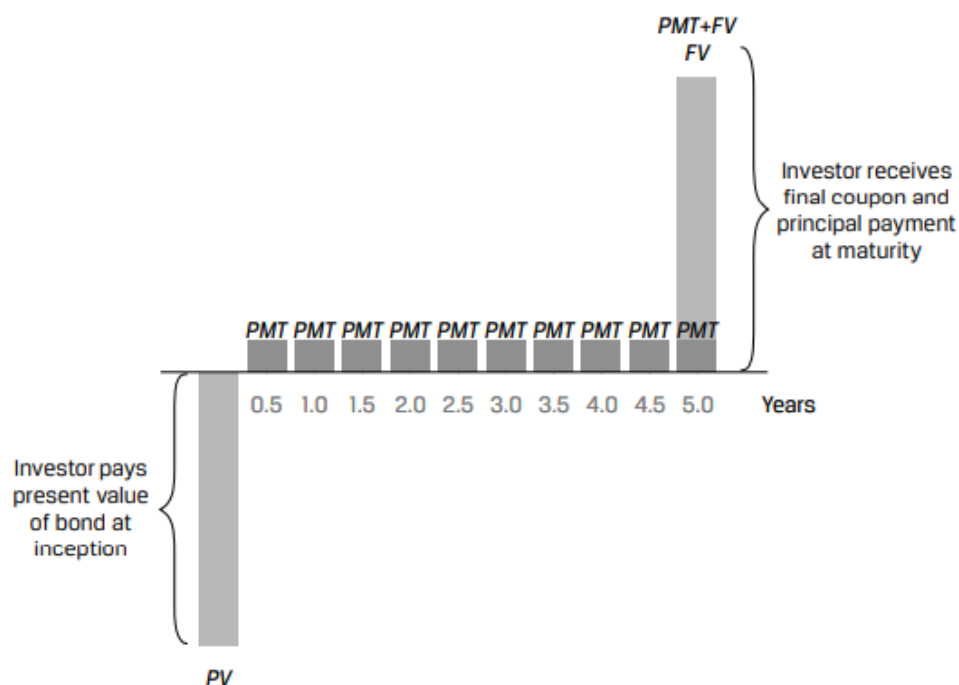

The present value of a coupon paying bond can be calculated as:

$$PV \text{ of bond} = \frac{PMT}{(1+r)^1} + \frac{PMT}{(1+r)^2} + \dots + \frac{PMT+FV}{(1+r)^N}$$

where:

PMT = coupon payment per period

FV = par value of the bond paid at maturity

r = market discount rate

N = number of periods until maturity

Example

The coupon rate on a bond is 4% and the payment is made once a year. The time to maturity is five years and the market discount rate is 6%. What is the bond price per 100 of par value?

Solution:

Start by drawing a timeline for the cash flows. The par value of the bond or principal is \$100. A coupon payment of \$4 is made every year. At maturity (at the end of five years), a payment of \$104 (principal of \$100 + coupon of \$4) is made.



We are required to calculate the present value of bond at time $t = 0$. For that, we discount all the future cash flows at the market discount rate of 6%.

End of year	Type of cash flow	Amount	Present value
1	Coupon	4	3.77
2	Coupon	4	3.55
3	Coupon	4	3.36
4	Coupon	4	3.17
5	Coupon + principal	104	77.71
			91.56

Using the formula, $PV = \frac{4}{1.06} + \frac{4}{1.06^2} + \frac{4}{1.06^3} + \frac{4}{1.06^4} + \frac{104}{1.06^5} = 91.575$

Note: The table and formula above were just for your understanding.

On the exam, solve this quickly using a financial calculator:

$N = 5$; $I/Y = 6$; $FV = 100$; $PMT = 4$; $PV = ?$ $PV = -91.575$

Perpetual bonds

A perpetual bond is a special type of coupon bond that has no stated maturity, i.e. it is expected to keep paying coupons perpetually. Companies may issue perpetual bonds to obtain equity like financing.

The present value of a perpetual bond can be calculated as:

$$PV \text{ of perpetual bond} = \frac{PMT}{r}$$

Example:

A bond pays an annual coupon of \$10 at the end of every year forever. Calculate the PV of this bond assuming a market discount rate of 5%.

Solution:

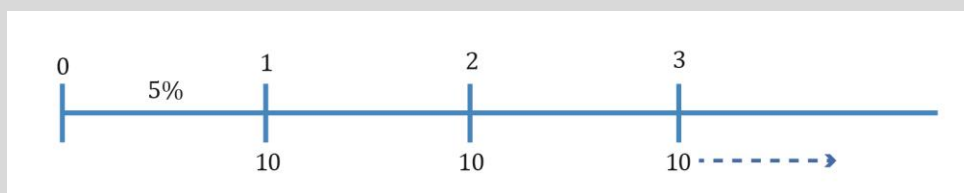

The PV of this perpetuity can be computed as:

$$PV = \frac{10}{0.05} = \$200$$

Instructor's Note:

Keep in mind that the present value of \$200 is one period before the first cash flow. Many students show the present value of \$200 at the same time as the first cash flow, which is incorrect.

Annuity instruments: They make periodic level (i.e. equal) payments consisting of both interest and principal. E.g. mortgages.

Exhibit 3 from the curriculum illustrates the cash flow pattern of a 30-year mortgage with monthly payments.

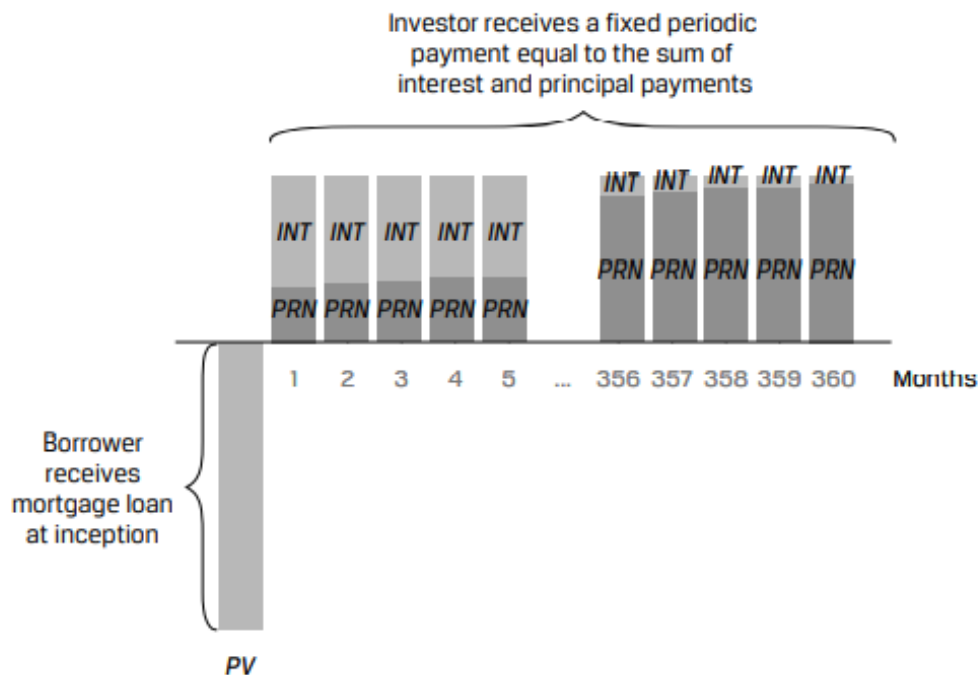

The periodic annuity cash flow (A) can be calculated as:

$$A = \frac{r(PV)}{1 - (1 + r)^{-t}}$$

Instructor's Note: Instead of remembering and using the above formula, we recommend that you use the TVM function of the calculator to solve for annuity payments. This is illustrated in the following example.

Example:

Freddie bought a car worth \$42,000 today. He was required to make a 15% down payment. The remainder was to be paid as a monthly payment over the next 12 months with the first payment due at $t = 1$. Given that the interest rate is 8% per annum compounded monthly, what is the approximate monthly payment?

Loan amount = 85% of \$42,000 = $0.85 \times 42,000 = \$35,700$

PV = $-\$35,700$

N = 12

I/Y = 8/12%

FV = 0 CPT PMT \rightarrow PMT = $\$3,105.48$

Equity Instruments and the Time Value of Money

One way of valuing equity instruments is as the present value of their expected dividends. Common assumptions used in dividend valuation models are:

- Constant dividend
- Constant dividend growth rate
- Changing dividend growth rate

Constant dividend: An investor pays an initial price (PV) for a share and receives a fixed periodic dividend (D) forever. Generally, preferred shares have such dividends.

Exhibit 4 from the curriculum illustrates the cash flow pattern of a stock with constant dividends.

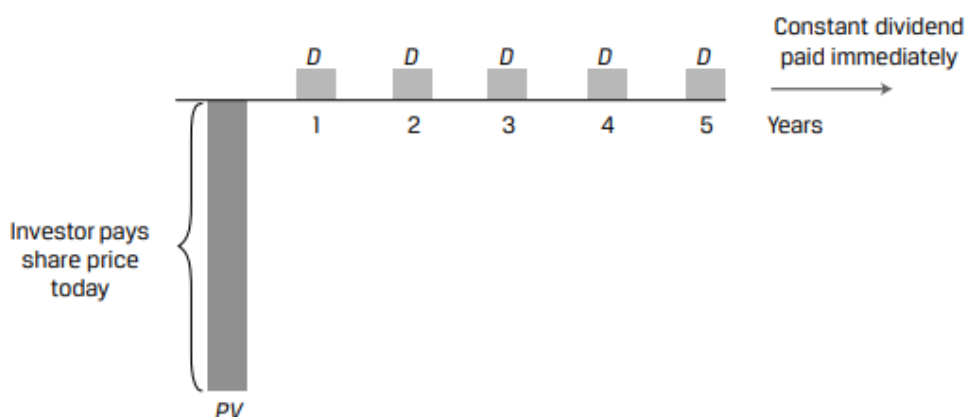

The PV of a stock with constant dividend is similar to the valuation of a perpetual bond. The PV is calculated as:

$$PV = \frac{D}{r}$$

where: V_0 = present value of the perpetuity; D_0 = dividend and r = rate of return

Example

A \$100 par value, non-callable, non-convertible perpetual preferred stock pays a 5% dividend. The discount rate is 8%. Calculate the expected stock price.

Solution:

Expected annual dividend = $0.05 \times 100 = 5$

Value of the preferred share = $5.00/0.08 = 62.50$

Constant dividend growth rate: An investor pays an initial price (PV) for a share and receives an initial dividend in one period (D_{t+1}). This dividend is expected to grow at a constant rate g forever.

Exhibit 5 from the curriculum illustrates the cash flow pattern of a stock with constant dividend growth rate.

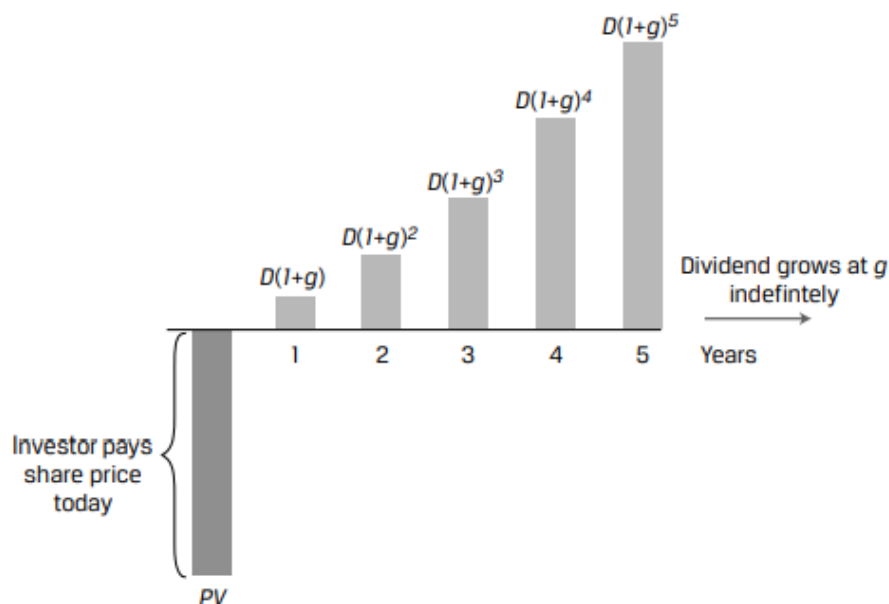

The present value of a stock with constant dividend growth rate can be found using the Gordon growth model. According to this model, the present value can be calculated as:

$$PV = \frac{D_1}{r - g}$$

where:

D_1 = next period's dividend

r = required rate of return

g = dividend growth rate

Instructor's Note: In the equation above, if the growth rate is zero, then the equation reduces to the present value of a perpetuity.

Example:

A company just paid a dividend of \$2.00. The dividend is expected to grow at 5% into perpetuity. The required return is 10%. What is the estimated stock price?

Solution:

$$PV = \frac{D_1}{r - g} = \frac{D_0 \cdot (1 + g)}{r - g} = \frac{2(1 + 0.05)}{0.10 - 0.05} = 42$$

Instructor's Note: Do not forget to use the next period's dividend i.e. \$2 growing at 5% in the formula. The PV using the unadjusted current period dividend is commonly presented as one of the answer options as a trap.

Changing dividend growth rate: It is an ideal situation to assume that all companies grow at a constant rate indefinitely and pay a constant dividend. The assumption is true to an extent only for stable companies. In reality, companies go through a finite rapid growth phase followed by an infinite period of sustainable growth.

A two-stage DDM can be used to calculate the value of such companies transitioning from growth to mature stage. The Gordon growth model may be used to calculate the terminal value at the beginning of the second stage which represents the present value of dividends during the sustainable growth phase.

$$PV = \sum_{t=1}^n \frac{D_0(1 + g_s)^t}{(1 + r)^t} + \frac{V_n}{(1 + r)^n}$$

The first term is discounting the dividends during the high growth period. The second term is calculating the terminal value for the second sustainable growth period and then discounting it to the present value where V_n = terminal value at time n estimated using the Gordon growth model.

Example

Let us understand the concept better with the help of an example. The current dividend for a company is \$4.00. The dividends are expected to grow at 20% a year for 4 years and then at 4% after that. The required rate of return is 18%. Estimate the intrinsic value.

Solution:

First draw a timeline.



We will use this formula:

$$PV = \sum_{t=1}^n \frac{D_0(1 + g_s)^t}{(1 + r)^t} + \frac{V_n}{(1 + r)^n}$$

where $n = 4$ (high growth period)

$$\text{Solve for the second term: } \frac{V_n}{(1+r)^n}; V_4 = \frac{D_5}{r-g} = \frac{D_4(1+g_L)}{r-g} = \frac{8.29 * 1.04}{0.18 - 0.04} = 61.58$$

Using the financial calculator, we can calculate the present value of dividends and terminal value by entering the following values: $CF_0 = 0$; $CF_1 = 4.8$; $CF_2 = 5.76$; $CF_3 = 6.91$; $CF_4 = 8.29 + 61.58$; $I = 18$; $NPV = 48.45$

Note: while calculating V_4 , you need to use 4% as growth rate since it is the long-term growth rate.

3. Implied Return and Growth

Market participants may sometimes face situations where both the present value (current market price) and future cash flows of an instrument are known. In such cases, we can solve for the implied return or growth rate that the market has incorporated into instrument's current market price.

Implied Return for Fixed-Income Instruments

The yield-to-maturity (YTM) is a bond's internal rate of return based on the assumption that the bond is held to maturity and all future cash flows occur as promised.

We can calculate the YTM implied by a bond's current market price for both discount and coupon paying bonds as illustrated in the examples below.

Example:

(This is based on Example 8 from the curriculum.)

Continuing with our previous example on discount bonds. Consider a 20 year zero coupon bond that will pay a par value of INR100 at maturity. The bond was initially issued at a price of INR27.33 and offered a 6.70% YTM. Six years later, the bond trades at a price (PV) of INR40.

1. What is the initial investor's implied return on this bond over the six-year holding period?
2. What is the expected return of a new investor who purchases the discount bond now at a price of INR40 and holds it till maturity?

Solution to 1:

Here $PV = -27.33$, $FV = 40$, $N = 6$, $PMT = 0$; $CPT \rightarrow I/Y = 6.55\%$

The investor received an annualized return of 6.55% which is slightly below the expected return of 6.70% at the time of issuance.

Instructor's note: The difference in returns is due to changes in market expectations about inflation and real interest rates. However, if the investor continues to hold the bond till maturity, he will receive exactly 6.70%, the YTM at issuance.

Solution to 2:

Here $PV = -40$, $FV = 100$, $N = 14$, $PMT = 0$, $CPT \rightarrow I/Y = 6.76\%$

The investor's expected return is 6.76%.

Example

The coupon rate on a bond is 4% and the payment is made once a year. The bond has a remaining maturity of 3 years and is currently trading in the market for \$95. What is the YTM of this bond?

Solution:

$$PV = -95, FV = 100, PMT = 4, N = 3, CPT \rightarrow I/Y = 5.86\%$$

The expected return on this bond is 5.86%. Note that this YTM calculation assumes that all intermediate cash flows (the coupon payments of \$4) can be reinvested at 5.86% through maturity.

Equity Instruments, Implied Return, and Implied Growth

The present value of an equity instrument reflects not only the required return but also the growth of cash flows. Under the assumption of constant growth of dividends, the PV of a stock was calculated as:

$$PV = \frac{D_1}{r - g}$$

Rearranging this equation, we get:

$$r - g = \frac{D_1}{PV}$$

$$r = \frac{D_1}{PV} + g$$

Thus, the implied return on a stock is equal to its expected dividend yield plus a constant growth rate.

We can also express the equation in terms of growth rate as:

$$g = r - \frac{D_1}{PV}$$

i.e., the implied growth rate of a stock can be calculated by deducting its expected dividend yield from its required return.

Example:

(This is based on Example 10 from the curriculum.)

Coca-Cola stocks currently trade at \$63.00 per share. Its annualized expected dividend per share during the next year is \$1.76.

1. If an analyst expects Coca-Cola's dividends to increase at a constant 4% per year indefinitely, calculate the required return expected by investors.
2. If the analyst believes that Coca-Cola investors should expect a return of 7%, calculate the implied dividend growth rate for Coca-Cola.

Solution to 1:

$$r = \frac{D_1}{PV} + g = \frac{1.76}{63} + 0.04 = 0.0679 = 6.79\%$$

Solution to 2:

$$g = r - \frac{D_1}{PV} = 0.07 - \frac{1.76}{63} = 0.0421 = 4.21\%$$

Instructor's note: For the same expected dividend and current price, a higher expected return implies a higher dividend growth rate and vice versa.

Price to Earnings Ratio

Instead of comparing stock prices directly, it is common practice to compare their price-to-earnings ratio (P/E). The P/E is a relative valuation metric that is calculated as share price/earnings per share. A stock trading at a P/E of 20 implies that investors are willing to pay 20 times earnings per share, and this stock is more expensive than a stock trading at a P/E of 10. P/E ratios are not only calculated for individual stocks but also for stock indexes such as the S&P 500.

We can link this relative valuation metric to the Gordon growth model as follows.

$$PV = \frac{D_1}{r - g}$$

Dividing both sides by E_1 (the expected earnings over the next period) we get:

$$\frac{PV}{E_1} = \frac{D_1/E_1}{r - g}$$

The LHS of the equation is the forward price-to-earnings ratio, the ratio of the current stock price to its next period expected earnings. The numerator on the RHS, D_1/E_1 , is the dividend payout ratio i.e., the proportion of earnings distributed to shareholders as dividends.

We can use these inputs to calculate the implied return and growth rate of a stock as illustrated in the examples below.

Example

(This is based on Example 11 from the curriculum.)

Suppose Coca-Cola stock trades at a forward P/E of 28 and its expected dividend payout is 70%.

1. If an analyst believes that Coca-Cola's dividends will grow at a constant rate of 4% per year, calculate Coca-Cola's required return.
2. If the analyst believes that Coca-Cola investors should expect a return of 7%, calculate the implied dividend growth rate for Coca-Cola.

Solution to 1:

$$\frac{PV}{E_1} = \frac{D_1/E_1}{r - g}$$

$$28 = \frac{0.7}{r - 0.04}$$

$$r = \frac{0.7}{28} + 0.04 = 0.065 = 6.5\%$$

Solution to 2:

$$\frac{PV}{E_1} = \frac{D_1/E_1}{r - g}$$

$$28 = \frac{0.7}{0.07 - g}$$

$$g = 0.07 - \frac{0.7}{28} = 0.045 = 4.5\%$$

If we already know the required return and growth rate of the stock, we can also use the expression derived above to evaluate if a stock is overvalued or undervalued.

Example:

(This is based on Example 11 from the curriculum.)

Suppose Coca-Cola stock trades at a forward P/E of 28 and its expected dividend payout is 70%. Analysts believe that Coca-Cola stock should earn a 9% and that its dividend will grow by 4.5% per year indefinitely. Evaluate if the stock is overvalued or undervalued.

Solution:

$$\frac{PV}{E_1} = \frac{D_1/E_1}{r - g}$$

Using the above inputs, we can see that this results in an inequality.

$$28 > \frac{0.70}{0.09 - 0.045} = 15.56$$

Coca-Cola's forward price-to-earnings ratio of 28 is much greater than 15.56, which is computed from the equation. Therefore, the stock appears to be overvalued.

4. Cash Flow Additivity

According to the cash flow additivity principle, cash flows indexed at the same point in time are additive. For example, if you have the following cash flows:



You cannot simply add these three numbers. You have to take each of these numbers and bring them to a particular point in time. Let's say that we find the present values at time zero for each of these cash flows.

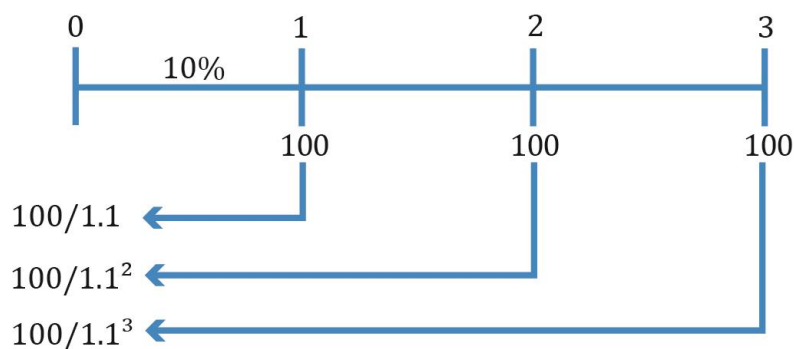

According to this principle, these present values that are all indexed to time zero can be added.

While valuing two cash flow streams, the cash flow additivity principle allows for the cash flow streams to be compared as long as the cash flows occur at the same point in time. This is illustrated in the example below:

Example:

(This is based on Example 12 from the curriculum.)

Assume that you have GBP100 to invest, and have two strategies to choose from with the following cash flow streams.

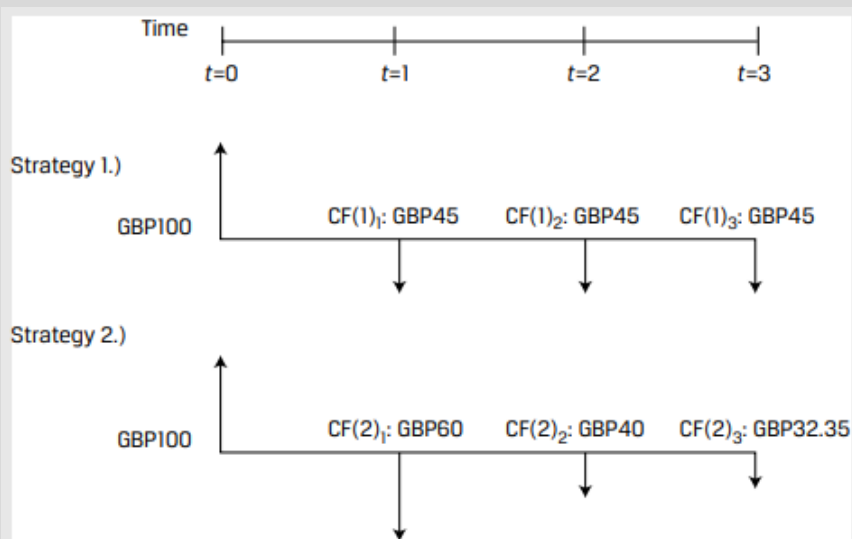

Your required return from both strategies is 10%. Recommend which investment strategy to choose.

Solution:

To compare the two strategies, we can calculate the difference between the cash flows at each time period and effectively create a new set of cash flows.

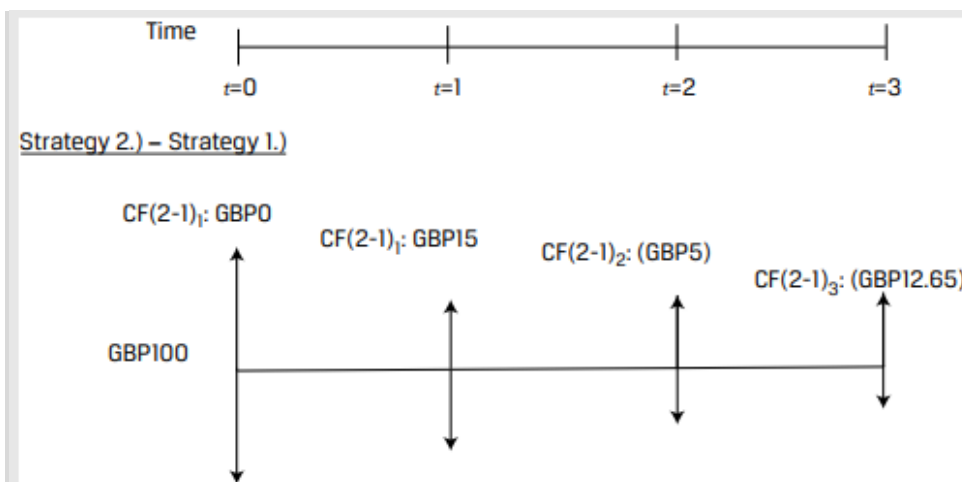

We then calculate the present value of these cash flows:

$$PV = 0 + \frac{15}{1.10} + \frac{-5}{1.10^2} + \frac{-12.65}{1.10^3} = 0$$

Since the PV is 0 the two strategies are economically equivalent. You should not prefer one over the other.

Instructor's Note: We calculated the difference in cash flows as Strategy 2 – Strategy 1. If we got a positive PV instead of a zero, it would indicate that strategy 2 is superior. And if we got a negative PV, it would indicate that strategy 1 is superior.

The cash flow additivity principle helps ensure that market prices reflect the condition of no arbitrage. Asset prices for economically equivalent assets are the same even if the assets have differing cash flow streams. Several real-world applications of cash flow additivity are presented below to illustrate no-arbitrage pricing.

Implied Forward Rates Using Cash Flow Additivity

A forward rate is the interest rate that is determined today for a loan that will be initiated at a future time period. $F_{A,B}$ represents a forward rate for a loan initiated A years from today with further maturity of B years. For example, $F_{2,3}$ represents the forward rate for a loan which starts at the end of year 2 and matured at the end of year 5.

Given a set of zero rates we can calculate the 'implied forward rates'. Consider the zero-rates below:

Years to Maturity	Zero Rate
1	2.3960%
2	3.4197%
3	4.0005%

Over a two-year period, an investor faces the following investment choices:

1. Invest USD100 for one year today at the zero rate (z_1) of 2.396% and reinvest the proceeds of USD102.40 at the one-year rate in one year's time, or the implied forward rate ($IFR_{1,1}$).
2. Invest USD100 for two years at the two-year zero rate (z_2) of 3.4197% to receive $USD100(1 + z_2)^2$, or USD106.96.

Based on the no-arbitrage principal both options should give the same results. Therefore,

$$USD100 \times (1 + z_1) \times (1 + IFR_{1,1}) = USD100 \times (1 + z_2)^2$$

$$(1 + z_1) \times (1 + IFR_{1,1}) = (1 + z_2)^2$$

$$(1.02396) \times (1 + IFR_{1,1}) = (1.034197)^2$$

$$IFR_{1,1} = 4.4536\%$$

This is illustrated in the figure below.

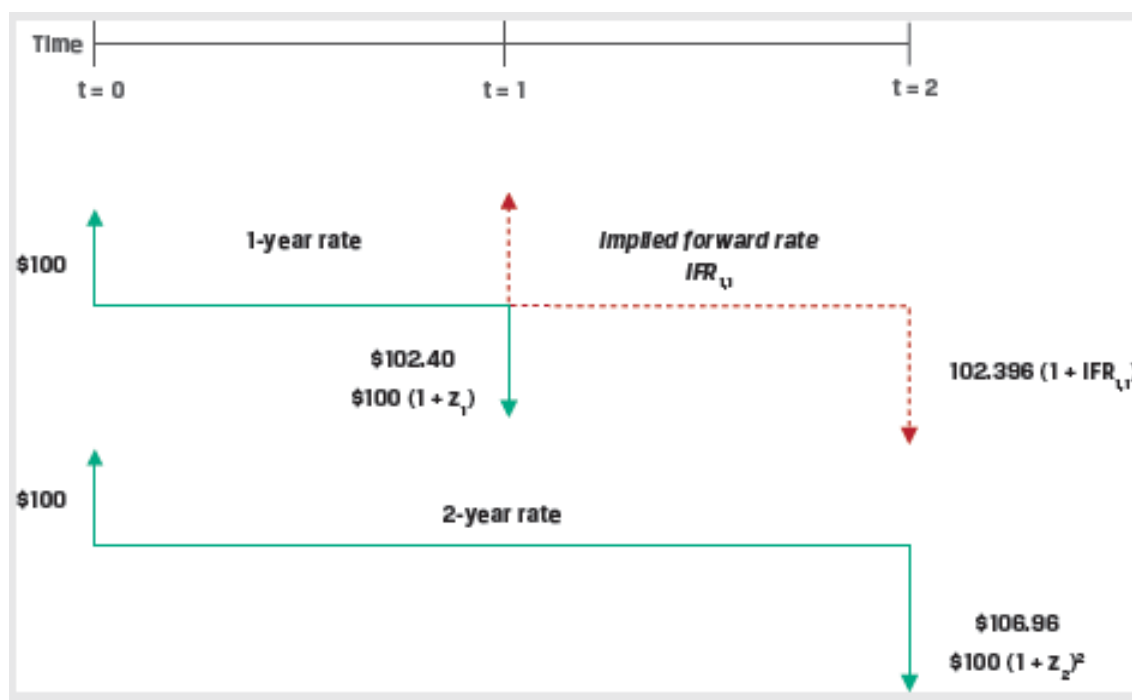

We can also solve for the one-period rate in two periods ($IFR_{2,1}$) as follows:

$$(1 + z_2)^2 \times (1 + IFR_{2,1})^1 = (1 + z_3)^3$$

$$(1.034197)^2 \times (1 + IFR_{2,1}) = (1.040005)^3$$

$$IFR_{2,1} = 5.1719\%$$

Forward Exchange Rates Using No Arbitrage

An exchange rate is the price or cost of one currency expressed in terms of another currency. Stated otherwise, it is the number of units of the price currency needed to buy/sell one unit of the base currency.

Consider an exchange rate quote of 1.4500 USD/EUR. The numerator currency (USD) is called as the price currency and the denominator currency (EUR) is called as the base currency. It implies that one EUR is exchangeable with 1.45 USD. So, 1.4500 USD/EUR is interpreted as \$1.45 per euro. Here, USD is the currency used to express price per one unit of euro.

A spot rate is the rate that is in effect today. A forward rate is a fixed exchange rate that we lock in today based on which currencies will be exchanged at some future date.

The forward exchange rate depends on relative interest rates in the two countries. To derive the relationship between spot rates, forward rates, and interest rates, assume you have one unit of domestic currency to be invested for let us say, one year. There are two options you may consider:

The exchange rate convention used = $\frac{\text{Foreign currency}}{\text{Domestic currency}} = \frac{\text{Price currency}}{\text{Base currency}}$

Option 1: Invest one unit of domestic currency (base currency) at the domestic risk-free rate i_B for one period.

Amount at the end of the period = $1 + i_B$

Option 2: Convert one unit of domestic currency into foreign currency (price currency) today using the spot rate $\frac{S_P}{B}$. Invest this amount at the foreign risk-free rate i_P for one period.

Determine the forward rate $\frac{F_P}{B}$ today at which the price currency will be converted back to base currency.

Amount of units of price currency at the end of the period = $\frac{S_P}{B} (1 + i_P)$

Amount in terms of base (domestic currency) at the end of the period = $\frac{S_P}{B} (1 + i_P) * \frac{1}{\frac{F_P}{B}}$

Note: By using forward rate, any foreign exchange risk was eliminated in this transaction.

Since the risk of these two investments is the same, they should generate equivalent returns. As an investor, you should be indifferent between the two as it is a no-arbitrage relationship.

$$1 + i_B = \frac{S_P}{B} (1 + i_P) * \frac{1}{\frac{F_P}{B}}$$

The above equation can be rewritten as:

$$\frac{F_P}{B} = \frac{S_P}{B} * \frac{1 + i_P}{1 + i_B}$$

where:

$\frac{F_P}{B}$ = forward rate

i_P = risk – free rate of the price currency

i_B = risk – free rate of the base currency

Let us use some values now to compute the forward rate. The spot rate for INR/USD $S_{\frac{\text{INR}}{\text{USD}}} = 100$.

The risk-free rate for INR is 10% and the risk-free rate for dollar (base currency) is 1%.

$$\text{Forward rate } F_{\frac{\text{INR}}{\text{USD}}} = S_{\frac{\text{INR}}{\text{USD}}} * \frac{1 + i_{\text{INR}}}{1 + i_{\text{USD}}} = 100 * \frac{1 + 0.1}{1 + 0.01} = 108.9108$$

This relationship ensures that there is no arbitrage. The only forward rate that prevents arbitrage is 108.91. Otherwise, for any rate greater/lesser than 108.91 traders can exploit the mispricing by buying low and selling high.

Option Pricing Using Cash Flow Additivity

Instructor's Note: This material is covered in greater depth later in the curriculum. At this point, only concentrate on gaining a basic understanding of the following example.

An option is a derivative contract that gives the buyer the right, but not the obligation, to buy or sell the underlying asset by a certain date (expiration date) at a specified price (strike price).

There are two kinds of options: Call options and put options. A call option confers the right to buy a stock at the strike price before the agreement expires. A put option gives the holder the right to sell a stock at a specific price.

Options can be valued using the binomial model. The binomial model assumes that over a given time period, there are only two possible outcomes - the stock's price will either go up to S_1^u or down to S_1^d . The following exhibit from the curriculum illustrates the binomial model.

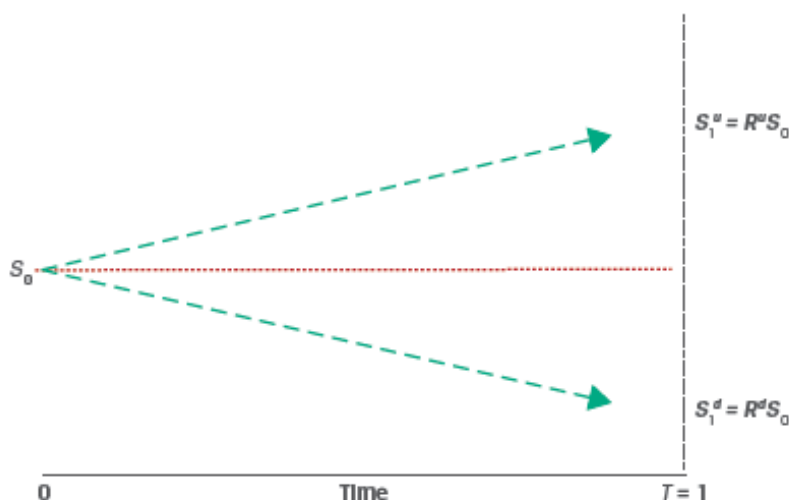

Pricing a call option:

Consider a one-year European call option with an exercise price (X) of 100.

The underlying spot price (S_0) is 80.

The two possible stock prices after 1 year are: $S_1^d = 60$ and $S_1^u = 110$

At $t = 0$, the call option value is c_0 .

At $t = 1$, the call option value is either c_1^u (if the price goes up) or c_1^d (if the price goes down). We can compute the values c_1^u and c_1^d as:

Up move: The call option ends in-the-money. The owner will choose to buy the stock at 100 and sell it in the market at 110.

$$c_1^u = 110 - 100 = 10$$

Down move: The call option ends out-of-the-money. The owner will not choose to buy the stock at 100 when the market price is only 60. So the option will expire worthless and have a value of 0.

$$c_1^d = 0$$

To compute c_0 we can use replication and no-arbitrage pricing. Assume that at $t = 0$ we sell the call option at a price of c_0 and purchase h units of the underlying asset. V_0 represents the initial investment in the portfolio, and V_1^u and V_1^d represent the portfolio value if the underlying price moves up or down, respectively.

$$V_0 = hS_0 - c_0$$

$$V_1^u = hS_1^u - c_1^u$$

$$V_1^d = hS_1^d - c_1^d$$

We solve for h , such that the portfolio payoff in both the up and down scenarios are equal, i.e.:

$$V_1^u = V_1^d$$

$$hS_1^u - c_1^u = hS_1^d - c_1^d$$

Solving for h , we get:

$$h = \frac{c_1^u - c_1^d}{S_1^u - S_1^d}$$

This equation gives us the hedge ratio, or the proportion of the underlying that will offset the risk associated with an option.

The hedge ratio for our example is:

$$h = \frac{c_1^u - c_1^d}{S_1^u - S_1^d} = \frac{10 - 0}{110 - 60} = 0.20$$

i.e. for each call option unit sold, we must buy 0.2 units of the underlying asset.

The portfolio values at $t=1$ for the up and down scenarios are:

$$V_1^u = hS_1^u - c_1^u = 0.20 \times 110 - 10 = 12$$

$$V_1^d = hS_1^d - c_1^d = 0.20 \times 60 - 0 = 12$$

As expected, the portfolio values are the same.

To prevent arbitrage, the portfolio value at $t=1$ should be discounted at the risk-free rate so that:

$$V_0 = \frac{V_1}{1+r}$$

For our example, $V_1=12$. Assume that the annual risk-free rate is 5%. Therefore,

$$V_0 = \frac{12}{1.05} = 11.42$$

Replacing V_0 by the hedged portfolio we get:

$$hS_0 - c_0 = 11.42$$

$$c_0 = hS_0 - 11.42 = 0.2 \times 80 - 11.42 = 4.58$$

The value of the call option at $t=0$ is 4.58.

Summary

LO: Calculate and interpret the present value (PV) of fixed-income and equity instruments based on expected future cash flows.

Fixed Income:

The present value (PV) of a zero-coupon bond can be calculated as:

$$PV = \frac{FV_t}{(1+r)^t}$$

The present value of a coupon paying bond can be calculated as:

$$PV \text{ of bond} = \frac{PMT}{(1+r)^1} + \frac{PMT}{(1+r)^2} + \dots + \frac{PMT+FV}{(1+r)^N}$$

The present value of a perpetual bond can be calculated as:

$$PV \text{ of perpetual bond} = \frac{PMT}{r}$$

Equity:

The PV of a stock with constant dividend is similar to the valuation of a perpetual bond. The PV is calculated as:

$$PV = \frac{D}{r}$$

The present value of a stock with constant dividend growth rate can be found using the Gordon growth model:

$$PV = \frac{D_1}{r - g}$$

The present value of a stock with changing dividend growth rate can be found using a two-stage model:

$$PV = \sum_{t=1}^n \frac{D_0(1+g_s)^t}{(1+r)^t} + \frac{V_n}{(1+r)^n}$$

LO: Calculate and interpret the implied return of fixed-income instruments and required return and implied growth of equity instruments given the present value (PV) and cash flows.

Fixed income: The yield-to-maturity (YTM) is a bond's internal rate of return based on the assumption that the bond is held to maturity and all future cash flows occur as promised.

We can calculate the YTM implied by a bond's current market price for both discount and coupon paying bonds by using the TVM function of a calculator.

Equity: The implied return on a stock is equal to its expected dividend yield plus a constant growth rate.

$$r = \frac{D_1}{PV} + g$$

We can also express this relationship in terms of P/E ratios:

$$\frac{PV}{E_1} = \frac{D_1/E_1}{r - g}$$

LO: Explain the cash flow additivity principle, its importance for the no-arbitrage condition, and its use in calculating implied forward interest rates, forward exchange rates, and option values.

According to the cash flow additivity principle, cash flows indexed at the same point in time are additive.

While valuing two cash flow streams, the cash flow additivity principle allows for the cash flow streams to be compared as long as the cash flows occur at the same point in time.

The cash flow additivity principle helps ensure that market prices reflect the condition of no arbitrage. Asset prices for economically equivalent assets are the same even if the assets have differing cash flow streams.

Implied forward rate: Given the one year and two year spot rates, the implied 1 year forward rate can be found as:

$$(1 + z_1) \times (1 + \text{IFR}_{1,1}) = (1 + z_2)^2$$

Forward exchange rate: Given the spot exchange rate and the interest rates in the price and base currencies, the forward exchange rate can be found as:

$$F_{\frac{P}{B}} = S_{\frac{P}{B}} * \frac{1 + i_P}{1 + i_B}$$

Option values: The binomial model assumes that over a given time period, there are only two possible outcomes - the asset's price will either go up to S_1^u or down to S_1^d .

The hedge ratio for a call option is calculated as:

$$h = \frac{c_1^u - c_1^d}{S_1^u - S_1^d}$$

To compute c_0 we can use replication and no-arbitrage pricing. Assume that at $t = 0$ we sell the call option at a price of c_0 and purchase h units of the underlying asset.

$$V_0 = hS_0 - c_0$$

$$V_1^u = hS_1^u - c_1^u$$

$$V_1^d = hS_1^d - c_1^d$$

To prevent arbitrage, the portfolio value at $t = 1$ should be discounted at the risk-free rate so that:

$$V_0 = \frac{V_1}{1+r}$$

or

$$hS_0 - c_0 = \frac{V_1}{1+r}$$